

BEHAVIOR OF PLATINUM STIMULATING ELECTRODES IN PHYSIOLOGICAL MEDIA

OBNAŠANJE PLATINASTIH STIMULACIJSKIH ELEKTROD V FIZIOLOŠKEM MEDIJU

JANEZ ROZMAN¹, B. PIHLAR², M. JENKO³

¹ITIS d.o.o. Ljubljana, Centre for Implantable Technology and Sensors, Lepi pot 11, 1001 Ljubljana, University of Ljubljana

²Faculty of Chemistry and Chemical Technology, Aškerčeva 5, 1001 Ljubljana

³Institute of Materials and Technology, Lepi pot 11, 1001 Ljubljana, Republic of Slovenia

Prejem rokopisa - received: 1998-12-04; sprejem za objavo - accepted for publication: 1998-12-14

Electrical stimulation of neuro-muscular system generates a response in excitable cells by an electrical field between two electrodes produced by the flow of ions, i.e., ionic current, in the biological fluid. The compatibility of a chronic neural prostheses requires that the electrical charge must be delivered without producing toxic reactions products or degrading the electrode. For a given electrode there is a limit to the quantity of charge that can be injected in either the anodic or cathodic direction with reversible surface processes. This limit will depend upon the size of the electrode, its geometry, and the parameters of the stimulating waveform. To determine this limit experimentally, knowledge of the potential range over which they can occur is required. The electrochemical technique of cyclic voltammetry can delineate an operational potential window between hydrogen and oxygen evolution. Keeping the electrode potential within this window during pulsing guarantees that water electrolysis reaction will not occur. The study reported here seeks to characterize platinum electrode behavior of the multielectrode spiral cuff system for selective stimulation of different superficial regions of peripheral nerves in a protein containing solution. Each platinum electrode of the cuff system had a flat geometric surface of 2 mm². In a typical cyclic voltammetry experiment, the potential of the tested electrode versus a Saturated Calomel Electrode (SCE) was cycled at an appropriate rate between two potential limits. All measurement have been carried out using a specially designed electrochemical cell at 37°C, and the Potentiostat/Galvanostat (Princeton Applied Research). Besides, investigations of surfaces of electrodes using high resolution AES method were performed.

Key words: platinum stimulating electrodes, peripheral nerves, voltammetry, electrical charge

Električna stimulacija živčno-mišičnega sistema povzroči z električnim poljem med dvema elektrodama tok ionov skozi živčno tkivo in s tem odgovor vzdražljivih celic. Biokompatibilnost kroničnih živčnih protez pa zahteva, da mora biti električni naboj doveden tako, da ne povzroča nastanka toksičnih produktov ali razkroja elektrod. Za dano elektrodo obstaja zgornja meja naboja, ki ga lahko vnesemo v anodnem ali katodnem delu stimulatorskega impulza ob reverzibilnih površinskih procesih. Ta je odvisna od velikosti elektrode, njene geometrije in parametrov ter oblike stimulatorskih impulzov. Za eksperimentalno določitev te meje je potrebno poznavanje območja elektrokemijskih potencialov, ki se lahko pojavijo na elektrodah. S tehniko ciklične voltametrije lahko določimo potencialno okno med izločanjem vodika in kisika. Z zadrževanjem potenciala elektrod znotraj tega okna ob stimulaciji lahko zagotovimo, da ne bo prišlo do elektrolize vode. Cilj te študije je bil določiti obnašanje platinastih elektrod znotraj večelektrodnega sistema v obliki spiralne objemke za selektivno stimulacijo posameznih površinskih področij perifernih živcev v fiziološkem mediju. Geometrijska površina posamezna elektroda znotraj spiralnega sistema je bila 2 mm². Pri eksperimentu s ciklično voltametrijo smo potencial testne stimulatorske elektrode glede na nasičeno Calomelovo elektrodo (SCE) ciklično in s primerno hitrostjo spreminjali med dvema zgornjima mejama potencialov. Vse meritve smo izvajali v posebej izdelani elektrokemijski celici pri temperaturi 37°C in s Potentiostat-om/Galvanostat-om (Princeton Applied Research). Narejene so bile tudi raziskave površin elektrod z visoko ločljivim Augerjevim spektroskopom.

Ključne besede: platinaste stimulatorske elektrode, periferni živci, voltametrija, električni naboj

1 INTRODUCTION

The electrical activation of nervous tissue provides a means to exert external control over body systems that are normally under control of the nervous system¹. For example, the activation of paralyzed muscles by electrical stimulation of intact lower motor neurons allows restoration of movements to persons with spinal cord injury, head injury, or stroke^{2,3}. In most of applications, at least one electrode is used to activate each muscle⁴. The aim of controlling larger numbers of muscles requires the implantation and maintenance of a large number of electrodes. To reduce the number of implanted electrodes in advanced motor prostheses, electrodes are required that can stimulate independently several muscles^{5,6,7}. However, the long-term use of electrical stimulation in this way requires that the stimulation be applied selectively

and without causing tissue injury. Tissue damage and stimulating electrode corrosion are both associated with high charge density stimulation^{8,9}. Long-term stimulation of the nervous system implies the absence of irreversible electrochemical reactions such as electrolysis of water, evolution of chlorine gas by oxidation of chloride, or the formation of metal oxides^{1,10}. During the application of the electrical pulse, the potential limits at which a significant amount of oxygen and hydrogen are formed should not be exceeded^{11,12}. Namely, as the application of an external potential on the electrode result in their polarization^{1,13,14}, the potential of the anode and cathode is shifted in the anodic and cathodic direction, respectively. In the presence of electrochemically active substances in the vicinity of the electrodes, oxidative processes on the anode and reductive reactions on the cathode occur¹. For a given electrode there is a limit to the quantity of charge

that can be injected in either the anodic or cathodic direction with reversible surface processes¹⁵. This limit will depend upon the size of the electrode, its geometry, and the parameters of the stimulating waveform. The safe limits for injection have been found to be much higher for balanced charge biphasic pulses than for monophasic pulses^{10,11}. Presumably, the charge delivered during secondary pulse reverses potentially toxic products generated during primary pulse¹. When long pulse widths are used or when a delay is introduced between the primary and the secondary pulse, there is more time for electrochemical reactions to occur. The unreversed products can lead to tissue damage, and in the case of balanced charge biphasic pulses can lead to excess anodic drift of the interpulse electrode during the anodic phase. This drift could possibly cause corrosion. To determine safe limits experimentally knowledge is required on the potential range over which reversible surface processes can occur^{9,13}. The electrochemical technique of cyclic voltammetry can delineate an operational potential window between hydrogen and oxygen evolution³. Keeping the electrode potential within this window during pulsing guarantees, that water electrolysis reaction will not occur. If the stimulating charge density exceeds this limit then the potential reached by the electrode will induce ionic flow by the faradaic reactions. The faradaic processes available on Pt have been classified as reversible or irreversible^{14,15}. Reversible charge injection limits for cathodic pulses range from 0.25 $\mu\text{Cb}/\text{mm}^2$ for some platinum electrodes to 35 $\mu\text{Cb}/\text{mm}^2$ for Ir oxide electrodes. Reversible reactions are those that can be quantitatively reversed by passing a current in the opposite direction, and do not produce new chemical species in the bulk of the solution. Irreversible faradaic reactions are those that involve soluble species in the tissue fluid and will lead to the production of new chemical species^{3,11,15}. The charge required for electrical stimulation with miniature stimulating electrodes often exceeds the limits for reversible charge injection and a small fraction of the charge is transferred by faradaic reaction^{3,14,16}. Accordingly, an important component in the design of electrical stimulation is the stimulating electrode itself; its properties determine the nature and kinetics of charge transfer between electron conduction in the external circuit and ionic conduction through electrolytes within the tissue. The study reported here seeks to characterize platinum electrode behavior of the 45-electrode spiral cuff system developed in our laboratory in physiological media for selective stimulation of superficial regions of peripheral nerves.

2 METHODS

Multielectrode spiral cuff

A 45-electrode cuff system with a spiral transverse cross section for selective stimulation of superficial regions of peripheral nerves was designed to be expand-

able so that it could be sized to fit around a nerve trunk^{5,6,7}. It was manufactured by bonding two 0.1 mm thick flexible silicone sheets together. One sheet stretched and fixed in that position was covered by a layer of adhesive. A second unstretched sheet was placed on top of the adhesive and the composite was compressed to a thickness of 0.3 mm. When released, the cuff curled into a spiral tube as the stretched sheet contracted to its natural length. The diameter of the cuff was related to the amount of stretch: the greater the stretch, the smaller the diameter. 45 rectangular electrodes with a width of 0.6 mm and length of 1.5 mm made of cold rolled and annealed 50 μm thick platinum ribbon (99.99% purity) were mounted on the third silicone sheet with a thickness of 0.1 mm. Then Teflon insulated, multistranded lead wires were connected to the electrodes. For experimental purposes, the junctions between platinum electrodes and lead wires were implemented using a special tin alloy. Electrodes were arranged in three parallel groups each containing fifteen electrodes with a distance of 0.5 mm between them, while the distance between the groups was of 6 mm. An electrode with a certain number within each of the three parallel groups had the same position, and accordingly, fifteen groups of three electrodes in the same line in a longitudinal direction were formed. The electrodes arranged on the silicone sheet were then bonded on the inner side of the mechanically opened spiral cuff. The completed spiral cuff with an inner diameter of 2.5 mm was then trimmed to a length of 20 mm as shown in **Figure 1**.

Evaluation of impedance and galvanometric behavior of stimulating electrodes

The impedance of single electrode within the spiral cuff was measured "in vivo" 20 days after implantation on the sciatic nerve of a Beagle dog¹⁷. In these measure-

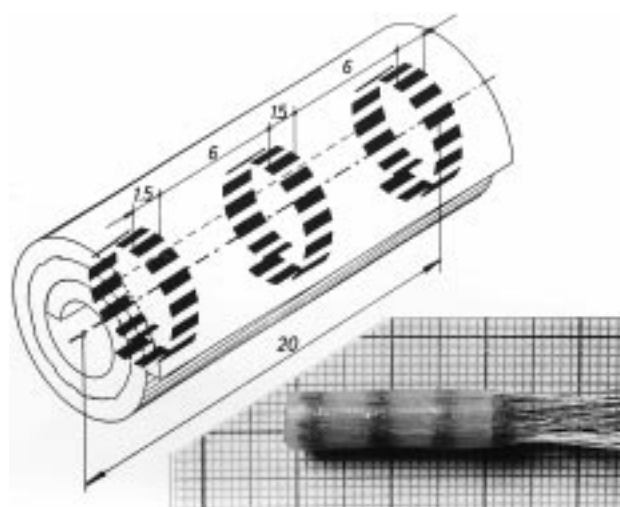

Figure 1: 45-electrode system for the selective stimulation of superficial regions of peripheral nerves

Slika 1: 45-elektrodni sistem za selektivno stimulacijo površinskih področij perifernih živcev

ments one stimulating electrode of the spiral cuff was connected to the impedance meter (Hewlett Packard) as the tested electrode while the large surface electrode, representing the common electrode when the stimulating system is implanted, was connected to the aforementioned instrument to complete the electrical circuit. Small electrodes of the spiral cuff are needed to affect as selective as possible the activation of small groups of nerve fibres^{18,19}. Moreover, it is necessary to depolarize axons at some distances from the electrode. Therefore, it is desirable to be able to inject enough charge. Platinum is capable of delivering the desired charge density solely by reversible processes. Each electrode of the spiral cuff had a flat geometric surface of 2 mm². The proposed biphasic rectangular and quasitrapezoidal cathodic first stimulating waveforms required for stimulation should result in low charge density. As shown below (equation 1), in the calculation of maximal charge that could be required in selective stimulation of superficial region of the dog in stimulating, cathodic part of rectangular stimulating pulse pair we proposed for current amplitude to be 1 mA, and for width to be 200 μs. The time delay between biphasic phases was settled to be 50 μs as shown in **Figure 2**, where the aforementioned and experimentally used current pulse pair is presented in upper trace and corresponding voltage waveform appeared between the stimulating electrodes in physiological solution (0.9% NaCl) in lower trace.

As the quantity of the reaction product generated by an electrochemical reaction is directly proportional to the absolute charge injected, we supposed that the proposed electrode delivering 100 nCb per pulse will not generate much product. In the evaluation of galvanometric behavior of single stimulating electrode within the spiral cuff the electrochemical technique of cyclic voltammetry was used. The main goal was to delineate an operational po-

tential window between hydrogen and oxygen evolution in a protein containing solution. In a typical cyclic voltammetry experiment, the potential of the tested stimulating electrode versus a SCE was cycled at an appropriate rate between two potential limits. Accordingly, the electrochemical cell, especially designed for this "in vitro" testing, included three electrodes: test or stimulating electrode, common electrode, and SCE. The test electrode was the electrode of primary interest while common electrode representing also the common electrode, when the stimulating system is implanted was required to complete the electrical circuit. It was also made of the same platinum ribbon where the geometric surface was 4 mm² as in real spiral cuff. One geometric mm² of a smooth platinum electrode corresponds to about 1.4 "real" mm². Therefore, the real surface of these electrodes may have been an area of 2.8 mm² for tested and 5.6 mm² for common electrode. Accordingly, the charge that could be injected through "real" surface of the electrode without changing charge density could be as high as 0.28 μCb. The same technique of cyclic voltammetry was used to determine the galvanometric behavior of the same electrode in the system in acid media (1M HClO₄). All measurements have been carried out using the aforementioned electrochemical cell at 37°C and the Potentiostat/Galvanostat, Model 273, Princeton Applied Research.

Evaluation of surface conditions of stimulating electrodes

The surface conditions electrodes obtained after injection the defined biphasic charge within certain period of time in physiological solution (0.9% NaCl), were analyzed using a high resolution AES method. For this purpose the same electrochemical cell and electrodes as described in the previous chapter were used. Moreover, the stimuli proposed in simulated long-term stimulation were again current, charge balanced, biphasic pulses with the delay of 50 μs between stimulating phases (**Figure 2**). Since we implant our systems in hemiplegic patients to correct their gait through selective stimulation of the common peroneal nerve, we simulated this stimulation in physiological solution (0.9% NaCl) for the time period of three years³. According to defined parameters of the proposed stimulating pulses, dimensions of stimulating electrodes and limits of safe stimulation, we calculated that the time of continuous stimulation required to simulate a three year period was equal to 30 days. In 30 days lasting experiment we injected approximately 15 Cb. After 30 days both electrodes, anode and cathode were cut out from the silicone spiral cuff, cleaned without any mechanical deformation and mounted on especial sample holder belonging to the machine (MICRO-LAB 310 F, VG-SCIENTIFIC) enabling surface analysis in ultra high vacuum using high resolution AES method.

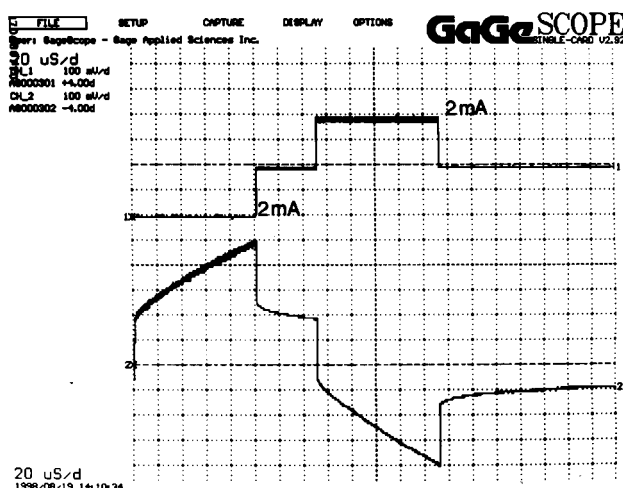

Figure 2: Current, charge balanced, biphasic pulses with the delay of 50 μs between phases

Slika 2: Tokovni, nabojsko uravnoteženi, izmjenični impulzi z zamikom 50 μs med fazama

$$Q/\text{mm}^2(\text{geometric})/\text{phase} = 1 \text{ mA} \times 200 \mu\text{s} / 2 \text{ mm}^2 = 0.1 \mu\text{Cb}/\text{mm}^2 \quad (1)$$

3 RESULTS

The relatively large contact ("real") area of tested electrode resulted in a low impedances $|Z|$ of platinum electrodes in the cuff^{9,17}. They appeared to be about 1.6 k Ω (measured at 1 kHz), and about 1.25 k Ω (measured at 10 kHz). A typical current versus potential curve, or cyclic voltammogram of one platinum electrode in Elliott's buffered solution, with pH 7.3 is shown in **Figure 3**. The composition of the Elliott's buffered solution: 7.3 g NaCl/l, 2.0 g NaHCO₃/l, 0.23 g Na₂SO₄/l, and 0.13 g NaH₂PO₄ x 2H₂O/l, pH was adjusted by addition of 0.1M HCl to 7.3. The mentioned cyclic voltammogram of the tested electrode (**Figure 3**) shows that in neutral media hydrogen evolution begins at about -0.8 V. The oxidation of the adsorbed hydrogen appears at about -0.7 V when potential is changed in positive direction, while the oxidation of the electrode surface and the decomposition of water begin at about 1.0 V. A train of the biphasic rectangular current pulses during stimulation therefore results in a series of potential steps between -0.8 and 1.0 V with respect to the SCE. The results of investigations of the anode and the cathode surface using high resolution AES method showed that both electrodes injecting biphasic charge in physiological solution for 30 days were covered by layers containing Sn, C and O, respectively. The layer covering the anode presented in **Figure 4** (upper part) was relatively thick, extending through complete surface while the layer covering the cathode was located at different sites across the surface having a shape of dendrites as shown in **Figure 5** (upper part). Spectra of kinetic energy representing an activity of constituting elements corresponding to anodic and cathodic layers are represented in the lower parts of **Figure 4** and **Figure 5**, respectively. It is obvious from **Figure 4** that the layer on the anodic surface prevented for the peak belonging to platinum to be visible. However, in the case of the layer on the cathodic surface some activity of a platinum could be observed. Presence of Sn in both layers could be explained by the fact that in the

technology of connecting lead wires to the electrodes within the spiral cuff a low temperature tin alloy containing Sn was used. Accordingly, during pulsing small amounts of Sn ions could be released from connections forming different complexes deposited as aforementioned layers on the surfaces of the electrodes. To avoid the process of forming depositions the whole experiment was repeated using the same setup and conditions as in 30 day simulated stimulation except the technology of connection the electrodes to the lead wires. In this case both electrodes were connected using technology of simple mechanical connection without third material. In **Figure 6** (upper part) a surface of mechanically connected cathode, pulsed with described stimulating pulses in physiological solution is presented. It is obvious that no contamination could be observed. Therefore, the last technology of mechanical connection could be a solution

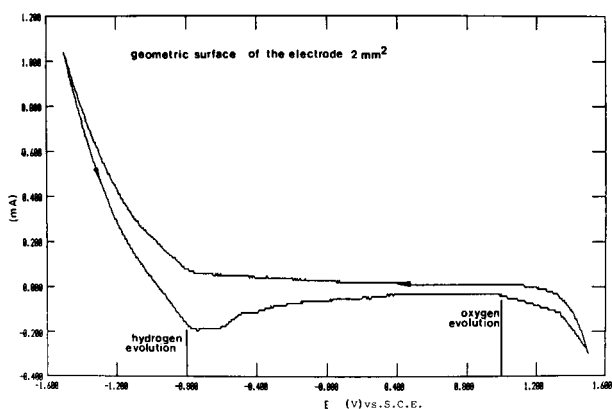

Figure 3: A cyclic voltammogram of one Pt stimulating electrode in Elliott's buffered solution
Slika 3: Ciklični voltamogram narejen na eni od platinastih elektrod v Elliott-ovi raztopini

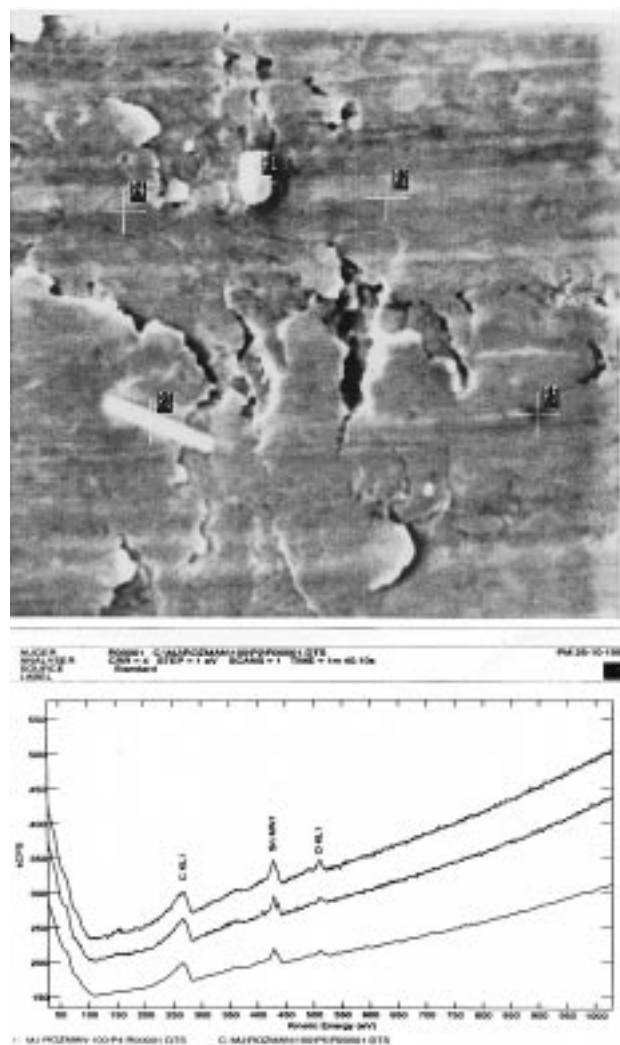

Figure 4: The surface of the anode covered by a thick layer (upper part) and an activity of it's constituting elements analyzed in site P2 (lower part)
Slika 4: Površina anode prekrita z debelo oblogo (zgornja slika) in aktivnost elementov, ki jo sestavljajo, analizirano v točki P2 (spodnja slika)

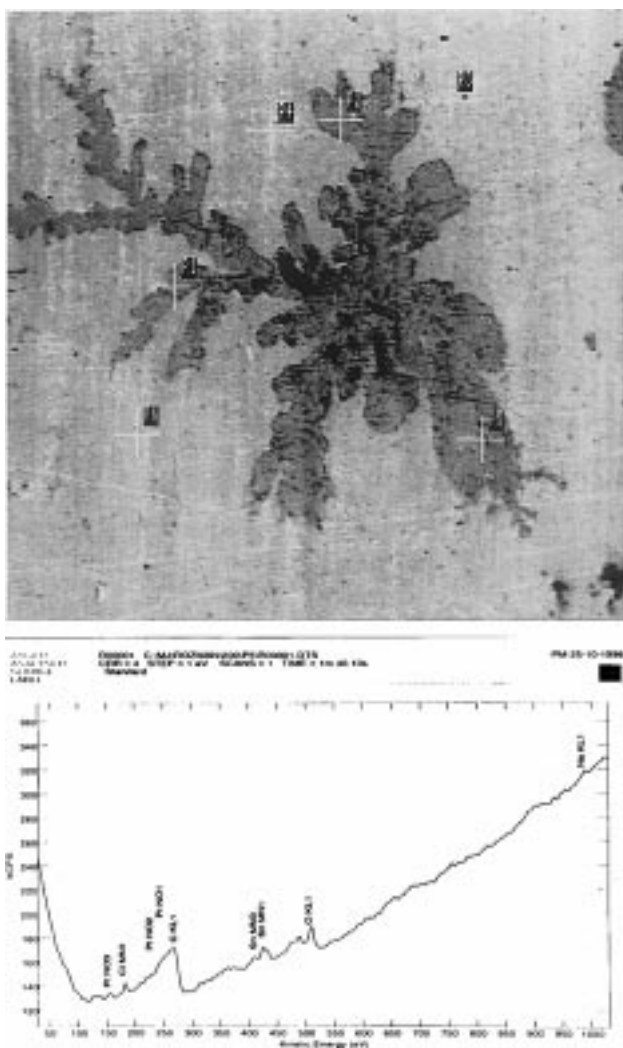

Figure 5: The surface of the cathode covered by the dendritic layer (upper part) and an activity of it's constituting elements analyzed in site P5 (lower part)

Slika 5: Površina katode prekrita z oblogami v obliki dendritov (zgornja slika) in aktivnost elementov, ki jih sestavljajo, analizirano v točki P5 (spodnja slika)

in further development of multielectrode systems for electrical stimulation of a nerve tissue.

4 DISCUSSION

For multielectrode stimulating systems containing miniature stimulating electrodes working at relatively high charge densities, it is very important that they are electrochemically stable, otherwise corrosion and other irreversible reactions cannot be excluded^{6,7,9,15,16}. The technology of such systems usually includes the use of different metals and, of course, connections between them. A perfect electrical insulation of all metals except the surface of stimulating electrode is necessary for the life time of the system, otherwise irreversible electrochemical reactions can occur. If a material of lead wires,

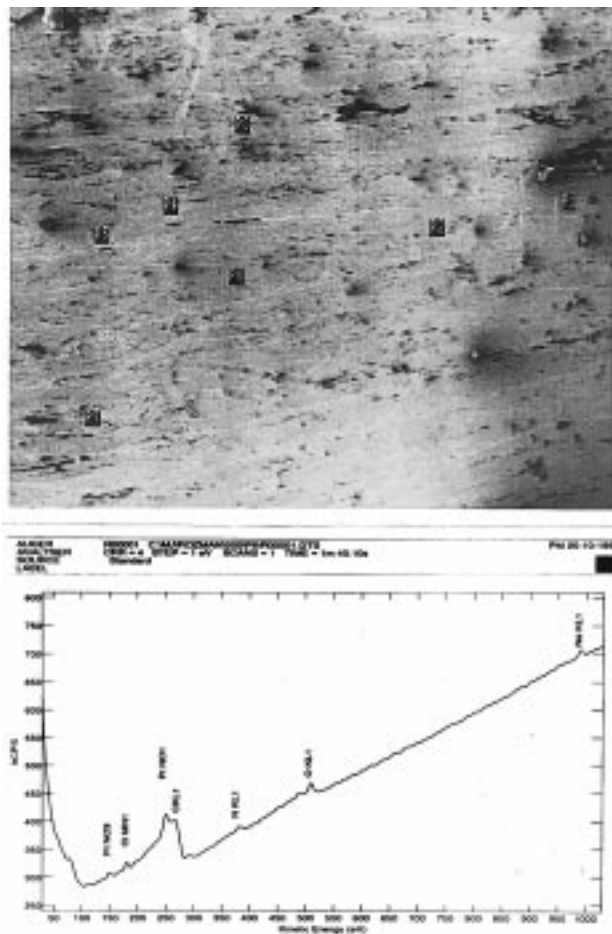

Figure 6: The surface of the cathode mechanically connected to the lead wire (upper part) and an activity of it's constituting elements analyzed in site P8 (lower part)

Slika 6: Površina katode mehansko povezane z dovodno žico (zgornja slika) in aktivnost elementov, ki jo sestavljajo, analizirana v točki P8 (spodnja slika)

which are usually made of multistranded or helically coiled stainless steel filaments, have the electrochemical contact with the physiologic media, electrochemical reactions can occur at high rates and electrodes can be destroyed or their surface contaminated as in our case.

Changes on the surfaces of stimulating electrodes after 3 year simulation of daily functional stimulation as observed using high resolution AES method cannot be attributed to corrosion, passivation etc., as a consequence of irreversible electrochemical reactions due to relatively high charge biphasic stimulating pulses. Even though the electrode operation in the cathodic part of the stimulating pulse pair in a reductive environment contributes to the pitting corrosion we could not observe any anomaly on the surface of electrodes which could be attributed to the corrosion.

Anomalies on the surface of the investigated electrode within 45-electrode spiral cuff system resulting from the deformations produced through long-term elec-

trical stimulation were identified only as layers of contamination on the surface of electrodes.

Since our tested electrodes were covered by layers containing mainly Sn it was necessary to change the technology of using tin alloy in connection electrodes to the lead wires with the technology of mechanical connection without using any third metal material.

Acknowledgement

This work was financed by Research Grant J2-7042-1326-95 from the Ministry of Science and Technology, Ljubljana, Republic of Slovenia.

5 REFERENCES

- ¹ J. T. Mortimer: Motor Prostheses. Pages 155-187 in *Handbook of Physiology*, Section 1. J. B. Brookhart and V. B. Mountcastle, (section eds.), V. B. Brooks (volume ed.), S. R. Geiger (executive ed.), American Physiological Society, Bethesda, MD., 1981
- ² A. Kralj, T. Bajd: Rehabilitation and functional electrical stimulation. *Current Opinion in Orthopaedics*, vol. 1 (1990) 455-461
- ³ J. Rozman, B. Pihlar, P. Strojnik: Surface examination of electrodes of removed implants. *Scand. J. Rehab. Med., Suppl.* 17 (1988) 99-103
- ⁴ W. F. Agnew, D. B. McCreery (Editors): *Neural Prostheses, Fundamental Studies*, Prentice-Hall, Inc., A Division of Simon & Shuster, Englewood Cliffs, New Jersey, 1990
- ⁵ G. G. Naples, J. T. Mortimer: A nerve cuff electrode for peripheral nerve stimulation. *IEEE Trans. Biomed. Eng.*, BME-35 (1988) 905-916
- ⁶ J. Rozman, B. Sovinec, B. Zorko: Multielectrode spiral cuff for ordered and reversed activation of nerve fibres. *J. Biomed. Eng.*, 15 (1993) 113-120
- ⁷ J. D. Sweeney, D. A. Ksienski, J. T. Mortimer: A nerve cuff technique for selective excitation of peripheral nerve trunk regions. *IEEE Trans. Biomed. Eng.*, BME-37 (1990) 706-715
- ⁸ D. B. McCreery, W. F. Agnew, T. G. H. Yuen, L. A. Bullara: Damage in peripheral nerve from continuous electrical stimulation: comparison of two stimulus waveforms. *Med. Biol. Eng. Comput.*, 3 (1992) 109-114
- ⁹ L. S. Robblee, T. L. Rose: Electrochemical guidelines for selection of protocols and electrode materials for neural stimulation. In *Neural Prostheses: Fundamental Studies*. W. F. Agnew, D. B. McCreery, Eds. Englewood Cliffs, Nj: Prentice-Hall, 25-66, 1990
- ¹⁰ M. D. Bonner, M. Daroux, T. Crish, J. T. Mortimer: The pulse-clamp method for analyzing the electrochemistry of neural stimulating electrode. *J. Electrochem. Soc.*, 140 (1993) 2740-2744
- ¹¹ N. de N. Donaldson, P. E. K. Donaldson: Where are actively balanced biphasic ('Lilly') stimulating pulses necessary in a neurological prostheses? II Historical Background; Pt resting potential; *Q studies. Med. & Biol. Eng. & Comput.*, 24 (1986) 41-48
- ¹² P. F. Johnson, L. L. Hench: An in vitro model for evaluating neural stimulating electrodes. *J. Biomed. Mater. res.*, 10, (1976) 907-928
- ¹³ S. L. Morton, M. Daroux, J. T. Mortimer: The role of oxygen reduction in electrical stimulation of neural tissue. *J. Electrochem. Soc.*, 141 (1994) 122-130
- ¹⁴ J. Rozman, B. Kelih, B. Pihlar: Potentials of platinum electrodes versus a Ag/AgCl reference electrode. *Proc. 2nd Vienna Int. Workshop on Functional Electrostimulation*, Vienna, (1986) 121-124
- ¹⁵ L. S. Robblee, T. L. Rose: The electrochemistry of electrical stimulation. *Proc. 12th Ann. Conf. IEEE Eng. in Med. & Biol. Soc.*, Philadelphia, (1990) 1479-1480
- ¹⁶ A. Scheiner, J. T. Mortimer, U. Roessmann: Imbalanced biphasic electrical stimulation: Muscle tissue damage. *Proc. 12th Ann. Conf. IEEE Eng. in Med. & Biol. Soc.*, Philadelphia, (1990) 1486-1487
- ¹⁷ L. A. Geddes, L. E. Baker: The specific resistance of biological material-A compendium of data for the biomedical engineer and physiologist. *Med. & Biol. Eng.*, 5 (1967) 271-293
- ¹⁸ P. H. Gorman, J. T. Mortimer: The effect of stimulus parameters on the recruitment characteristics of direct nerve stimulation. *IEEE Trans. Biomed. Eng.*, BME-30 (1983) 407-414
- ¹⁹ W. M. Grill, J. T. Mortimer: The effect of stimulus pulse duration on selectivity of neural stimulation. *IEEE Transactions on Biomedical Engineering*, 43 (1996) 161-166